

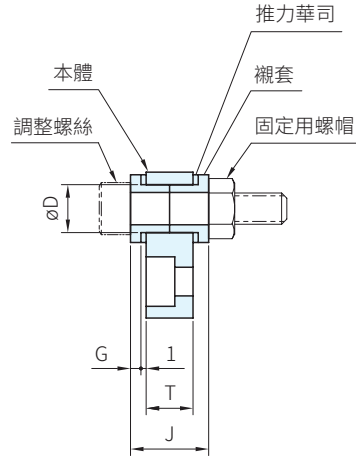

材質	處理
SS400	染黑
SUS304	-

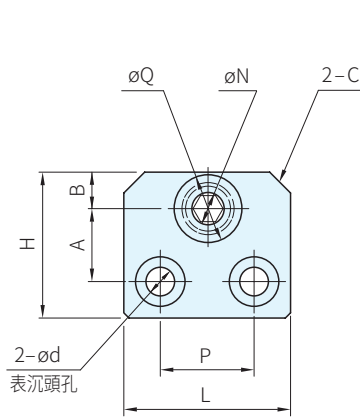

鐵品號	庫存	不銹鋼品號	庫存	調整螺絲	L	H	T	A	P	B	J	G	N	D	Q	C	d
WAT-BLA04D12Z	△	WAT-BLA04D12S	△	M4	22	23	6	12	12	6	11	1.5	4.2	6.8	11	3	3.5(M3用)
WAT-BLA05D13Z	△	WAT-BLA05D13S	△	M5	25	25	9	13	14	6	14	2	5.2	8	12	4	4.5(M4用)
WAT-BLA06D14Z	△	WAT-BLA06D14S	△	M6	32	28		14	18		7		15	6.2	9.2		13
WAT-BLA08D16Z	△	-	-	M8	38	32	12	16	22	8	18	2.5	8.3	12	16	6	6.6(M6用)
WAT-BLA10D20Z	△	-	-	M10	44	40	16	20	25	10	23		10.3	14.5	20		9(M8用)

**Ps.** 備註

· 亦可使用在張力調整器

訂貨：  交期：    
WAT-BLA04D12Z

**Ex.** 使用例

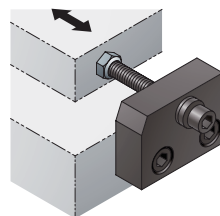
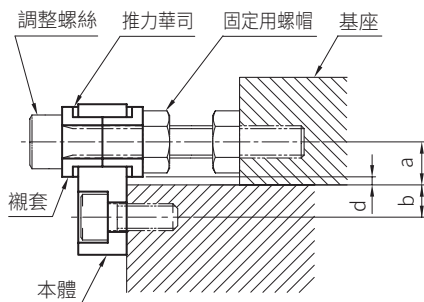

· 螺絲、螺帽需個別購買

調整螺絲	寸法(mm)		
	a	b	d
M4	7	5	1.5
M5	8		2
M6	10	6	1.5
M8		8	2
M10	12	8	

d：螺帽和本體上面的最小間隙